

SCHMEISER®
MODEL '77
ORCHARD LEVELER

ASSEMBLY & PARTS
MANUAL

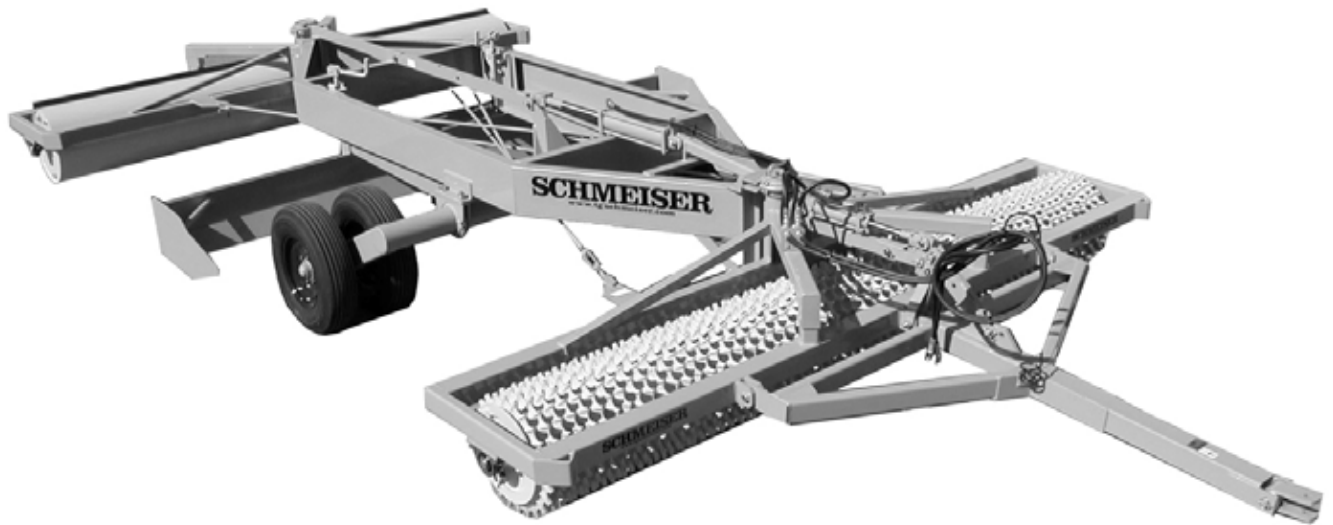

T. G. SCHMEISER CO., INC.

P.O. BOX 1047 FRESNO, CA 93714-1047
(559) 268-8128 FAX (559) 268-3279
www.tgschmeiser.com

VERSION 2.3
12 – 2011

©COPYRIGHT 2011 T.G.SCHMEISER CO., INC.

INTRODUCTION

Your Schmeiser Model '77 Orchard Leveler is designed to give you many years of dependable service. This manual has been prepared to instruct you in the safe and efficient operation of this machine. Read and study it thoroughly. Follow all instructions carefully.

Should your Model '77 Orchard Leveler require replacement parts, go to your Schmeiser dealer. Always order genuine Schmeiser replacement parts.

It is important that you complete and send in your Warranty Card because it is not valid unless it is on file at Schmeiser. If you need information not contained in this manual, contact your Schmeiser dealer.

Space has been provided below for you to record the model number and serial number of your Model '77 Orchard Leveler. Be sure to bring this information with you to your dealer when ordering parts for your Model '77 Orchard Leveler.

Thank you for buying a Schmeiser Model '77 Orchard Leveler.

SERIAL NUMBER _____

MODEL NUMBER _____

DATE PURCHASED _____

DEALER NAME _____

TABLE OF CONTENTS

Introduction	2
Table of Contents.....	3
Safety Sheet.....	4
Orchard Leveler Assembly Instructions.....	5
Orchard Leveler Complete Assembly.....	8
Front Linkage Assembly.....	10
Front Roller Assembly.....	11
Wheel Axle Bearing Assembly.....	12
Bucket Crank Assembly.....	13
Orchard Leveler Wheel Axle Assembly.....	14
Rear Split Roller Assembly.....	15
Orchard Leveler Hydraulic Diagram.....	16
Limited Warranty.....	17
Maintenance and Repair Record.....	18
Notes.....	19

SAFETY

The safe operation of any machinery is an important concern to farmers and manufactures. There are obvious and hidden potential hazards involved in the operation of this implement. Carefully read and follow all safety precautions before operation. Serious injury or death may occur unless care is taken to insure the safety of both the operator and any other persons in the area.

1. Never permit anyone to ride on or walk beside the implement when moving.
2. Never permit anyone to ride on tractor when implement is being moved.
3. When performing operating functions, never allow anyone to be near the implement or the tractor.
4. Do not enter tractor when tractor is moving. Avoid serious injury or death from contact with rotating tires. Enter and exit the tractor only when it is completely stopped.
5. Be sure of water, gas, sewer, or electric line locations before operating implement.
6. When in transport, use accessory lights and devices for adequate warning to operators of other vehicles. Comply with all Federal, State and local laws when traveling on public roads.
7. Use "Slow Moving Vehicle" emblem for warning vehicles approaching from the rear.
8. When transporting, remember that the implement may be wider than your tractor and extreme care must be taken to allow for safe clearance.
9. Never allow inexperienced or untrained personnel to operate the implement or tractor without supervision.
10. When using compressed air to clean implement, wear safety glasses.
11. Check all fasteners for tightness or damage before and after operation. Repair immediately if required.
12. Store implement in a stable position. Insure that safety stands are extended and locked in place before detaching from tractor.

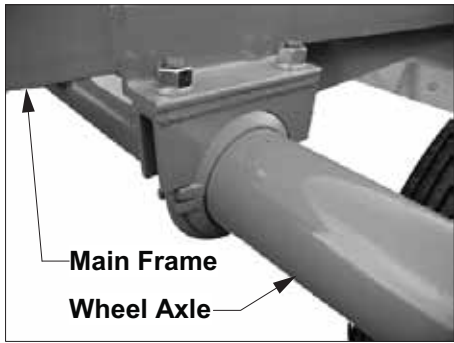
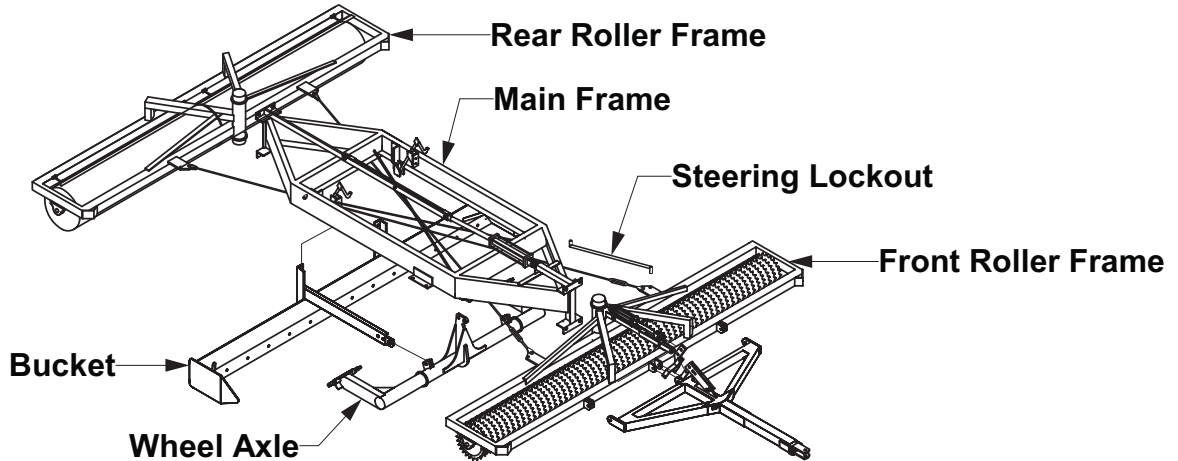

1. Place the bucket and wheel axle with front of bucket facing tires on wheel axle on the level ground. Place the main frame on top of both with hydraulic cylinder facing forward. Bolt wheel axle to main frame using (2) 1" axle bearing assemblies (see axle bearing assembly drawing on page 12 for details). Tighten all hex nuts.

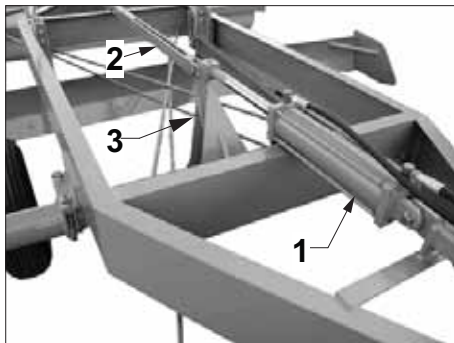

2. Connect 4" x 16" hydraulic cylinder (1) to wheel axle lever arm (3). Use smaller hole. Place main frame cylinder lockout bar (2) on top of the main frame and connect to wheel axle lever arm (3). Use 1-1/8" x 3" yellow clevis pin with 5/16" cotter pin. Connect other side of lockout bar to the main frame using 1-1/8" x 3" red clevis pin with 1/4" lynch pin.

3. Install bucket pull arm pins through bucket arm and wheel axle clevis.

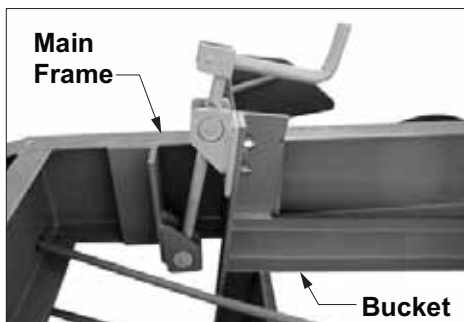

4. Install crank trunnions in main frame. Zerks should face inside of the main frame. Bolt bucket screw assembly to bucket. Screw crank into trunnion. Zerks should face inside of the main frame (see page 13 for crank assembly).

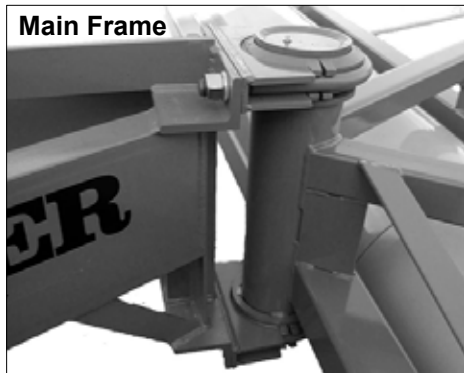

5. Locate front and rear roller frames. First, connect rear frame with smooth roller to main frame using (2) 1" axle bearing assemblies. Then, connect front frame with ring roller to main frame using (2) 1" axle bearing assemblies (refer to axle bearing assembly drawing on page 12 for details).

6. Mount pull frame with attached hitch control adjustment link to the front roller frame with 2-1/2" x 8" tie rod cylinder, hitch control pivot link, and wishbone link already attached (see drawing on page 9 for reference).

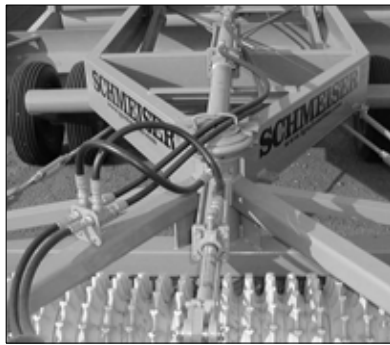

7. Mount hydraulic cylinder manifold with attached hoses to the front roller frame. Connect short hoses to 2-1/2" x 8" cylinder, long hoses to 4" x 16" cylinder (refer to hydraulic diagram on page 16 for proper installation).

8. Mount tires and wheels to the wheel axle (refer to wheel axle assembly drawing on page 14 for details).

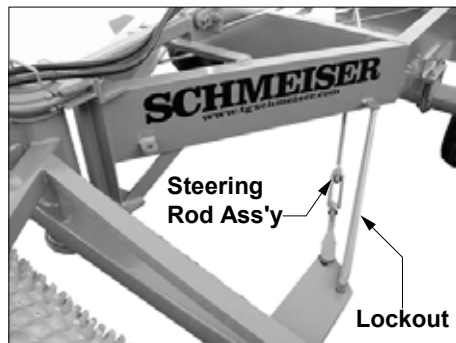

9. Square rear roller frame with bucket, and front roller frame with rear roller frame. Measure diagonally to the corners on the roller frames, adjust steering rod turnbuckles for square. Install steering lockout arm at left front corner.
10. Connect long rear steering rods, then short front steering rods in slotted holes. Put (4) yellow 3/4" x 2-1/2" pins with 5/16" cotter pins. Adjust turnbuckles if necessary to keep both roller frames parallel.



TO TRANSPORT ORCHARD LEVELER



1. Raise leveler up on hydraulics.
2. Install locking pin in hitch control sleeve(1). Install pin connecting hitch control pivot link and hitch control wishbone link (2). Install red locking pin (3) in main frame lockout bar.
3. Connect steering lockout (4) to front roller frame.

FIELD OPERATING INSTRUCTIONS

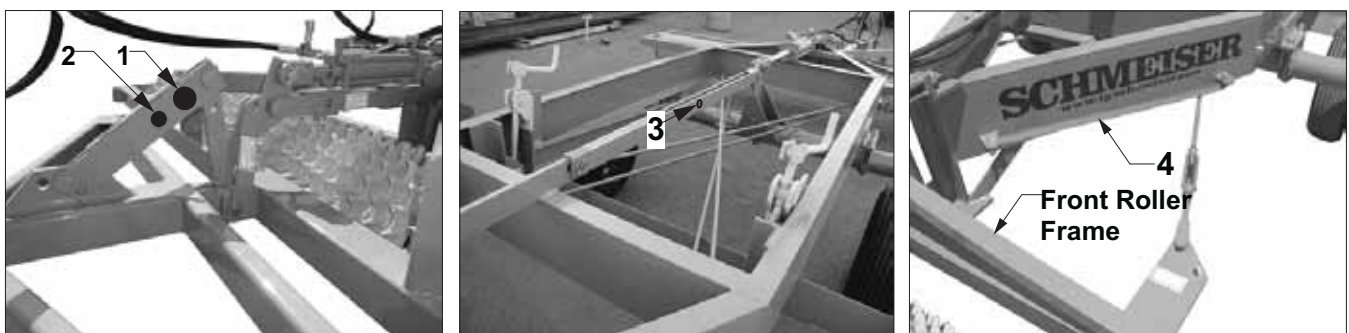

1. Pull locking pin for hitch control sleeve, and install in pin storage hole (1). Pull pin connecting hitch control pivot link and hitch control wishbone link and place in storage hole (2).
2. Pull locking pin for main frame lockout bar and place in storage hole (3).
3. Disconnect steering lockout (4) from axle and connect to storage clip on top frame.



<u>Ref No.</u>	<u>Part No.</u>	<u>Description</u>	<u>Qty.</u>
1.	SOL-(00)H100	Rear Roller Frame (specify size)	1
2.	SLL 1525L	Bearing Crank Assembly LH	1
	SLL 1525R	Bearing Crank Assembly RH	1
3.	SOL-00C100	OL Main Frame Weldment	1
4.	GHC-40160T	4" X 16" Tie Rod Hydraulic Cylinder	1
5.	GHC-25080T	2-1/2" X 8" Tie Rod Hydraulic Cylinder	1
6.	SOL-(00)B400	Front Roller Frame (specify size)	1
7.	TPP3021	3-1/2" Clevis Weldment	1
8.	SOL-00A100	OL Tongue Clevis Pin Weldment	1
9.	SOL-00A200	OL Pull Frame Weldment	1
10.	SLL1202	Hitch Control Wishbone Link Weldment	1
11.	SLL1201	Hitch Control Adjustment Link Weldment	1
12.	SLL1203	Hitch Control Pivot Link	1
13.	SLL1204	Hitch Control Sleeve Weldment	1
14.	SOL-00E200	OL Wheel Axle Weldment	1
15.	SLL1510	OL Bucket Blade 10 Ft. Units (includes items ## 29, 30, 31)	1
	SLL1511	OL Bucket Blade 11 Ft. Units (includes items ## 29, 30, 31)	1
	SLL1512	OL Bucket Blade 12 Ft. Units (includes items ## 29, 30, 31)	1
	SLL1514	OL Bucket Blade 14 Ft. Units (includes items ## 29, 30, 31)	1
16.	SOL-(00)F000	OL Bucket Weldment (specify size)	1
17.	SLL-MS10	10 Ft. Mud Scraper Weldment	1
	SLL-MS11	11 Ft. Mud Scraper Weldment	1
	SLL-MS12	12 Ft. Mud Scraper Weldment	1
	SLL-MS14	14 Ft. Mud Scraper Weldment	1
18.	SOL-00J200	OL Differential Shaft Weldment	1
19.	SOL-(00)J100	OL Split Roller Weldment (specify size)	2
20.	SOL-00D200	OL Long Steering Rod Weldment	2
21.	GTB-12X96W	Turnbuckle Assembly Weldment (Body with Short Stub)	2
22.	SLL1603	OL Steering Lockout Bar	1
23.	SLL1475	OL Wheel Axle Cylinder Lockout Bar	1
24.	GPN-18X044	1-1/8" X 2-3/4" Red Lockout Pin	1
25.	GPN-18X040	1-1/8" X 2-1/2" Yellow Standard Pin	1
26.	SOL-00E300	1-1/8" X 2-1/2" Coped Pin	2
27.	GPN-05X40C	5/16" X 2-1/2" Cotter Pin	7
28.	CSNC510028	5/8" X 1-3/4" NC Cap Screw Gr.5	4
29.	LWASHER-10	5/8" Lock Washer	varies
30.	HXNUT-10NC	5/8" NC Hex Nut	varies
31.	PBNC-10028	5/8" X 1-3/4" NC Plow Bolt	varies
32.	SOL-00F007	OL Bucket Pivot Pull Plate	2
	SLL1702	OL Split Roller with Differential Shaft for 10 Ft. Units (includes items 18 and 19 for 10 Ft. Units)	
	SLL1703	OL Split Roller with Differential Shaft for 11 Ft. Units (includes items 18 and 19 for 11 Ft. Units)	
	SLL1704	OL Split Roller with Differential Shaft for 12 Ft. Units (includes items 18 and 19 for 12 Ft. Units)	
	SLL1705	OL Split Roller with Differential Shaft for 14 Ft. Units (includes items 18 and 19 for 14 Ft. Units)	



T. G. SCHMEISER CO., INC.

ORCHARD LEVELER COMPLETE ASSEMBLY

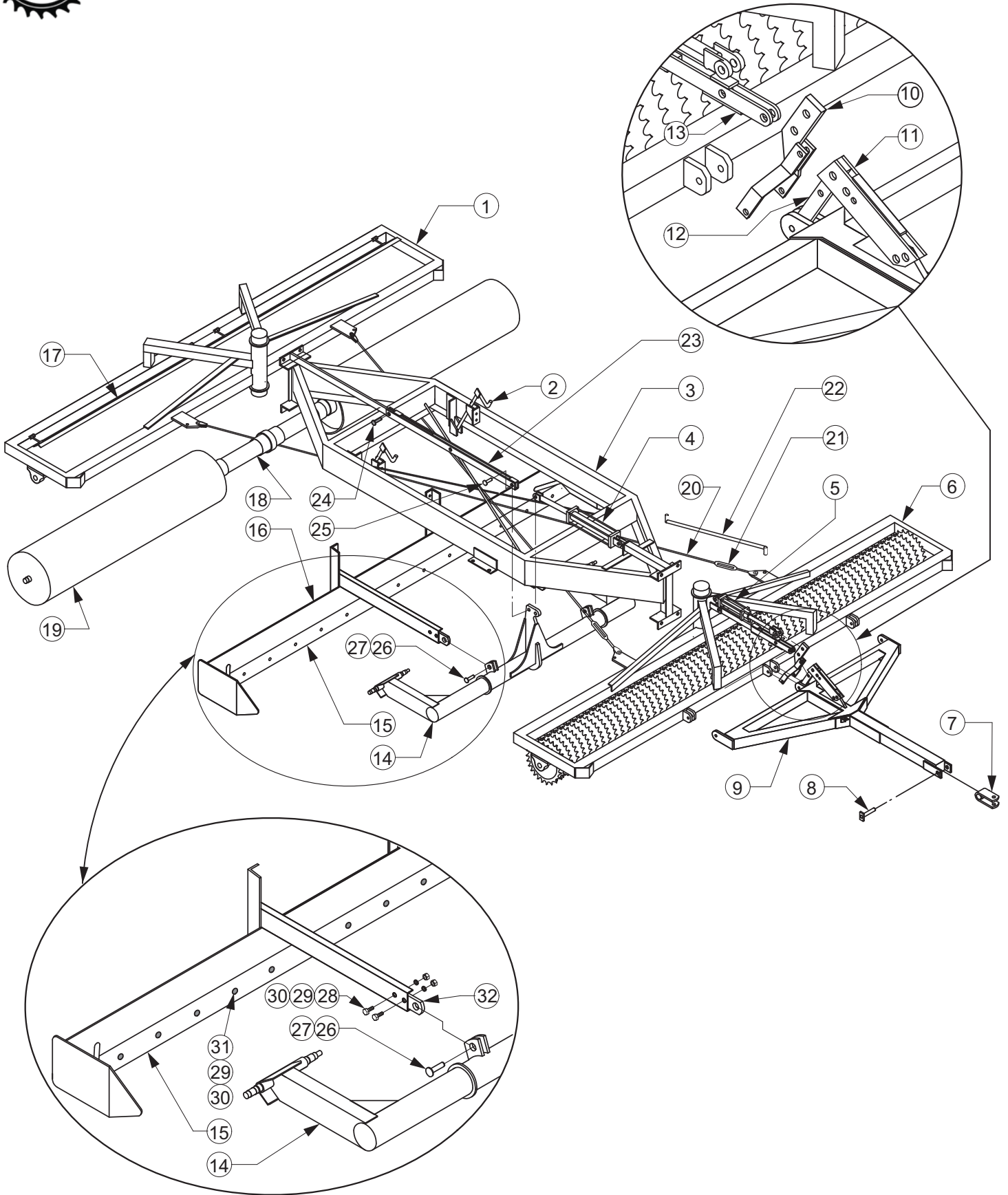

(559) 268-8128

Fax (559) 268-3279

www.tgschmeiser.com

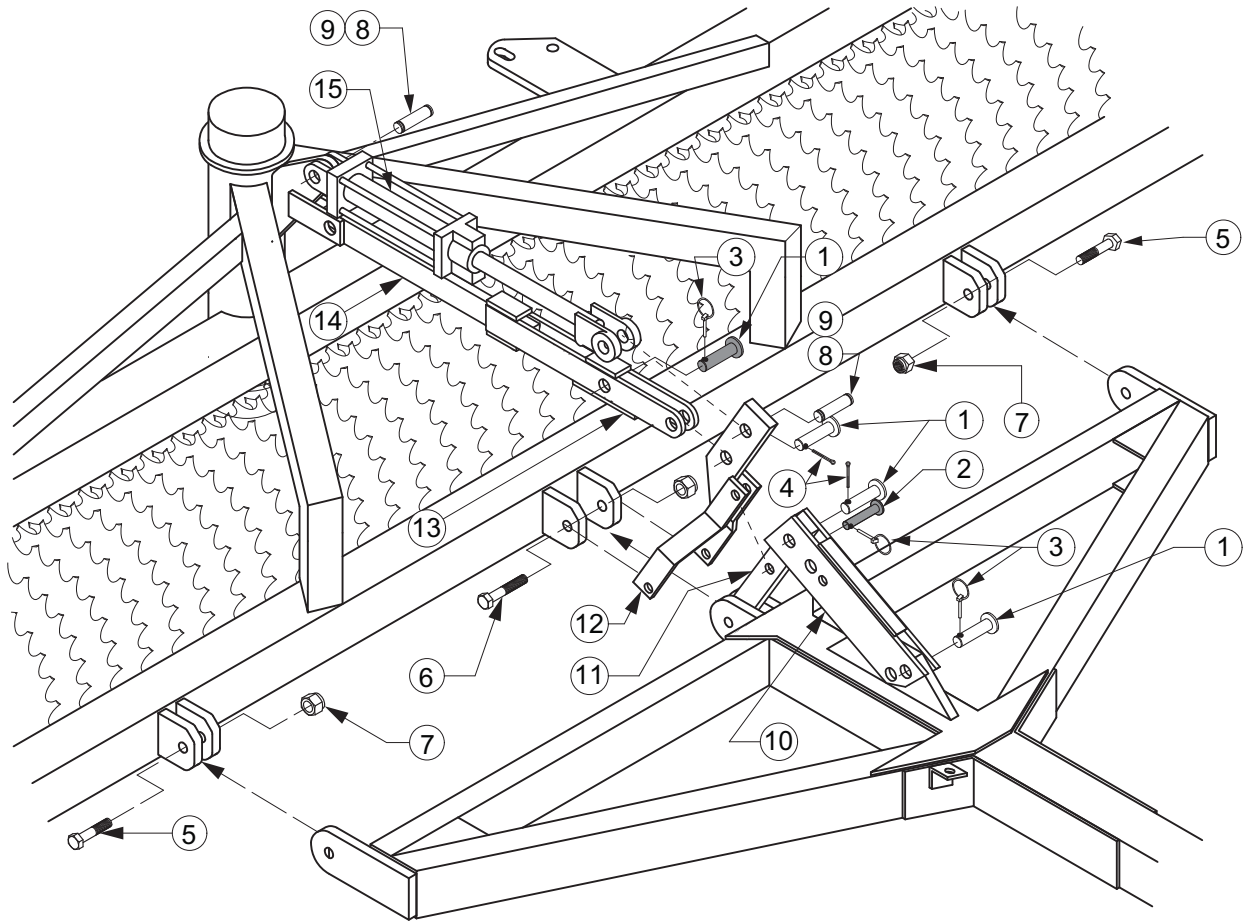

<u>Ref No.</u>	<u>Part No.</u>	<u>Description</u>	<u>Qty./ Unit</u>
1.	GPN-16X040	1" X 2-1/2" Clevis Pin (3 yellow and 1 lockout red pin)	4
2.	GPN-12X040	3/4" X 2-1/2" Clevis Pin (lockout red pin)	1
3.	GPN-040LYN	1/4" Lynch Pin	3
4.	GPN-05X40CT	5/16" X 2-1/2" Cotter Pin	2
5.	CSNC512064T	3/4" X 4" NC Cap Screw Gr.5	2
6.	CSNC512104	3/4" X 6-1/2" NC Cap Screw Gr.5	1
7.	NYNUT-12NC	3/4" NC Nylon Lock Nut	3
8.	GPN-1656HC	1" X 3-1/2" Cylinder Pin	2
9.	GPN-03CLIP	5/32" X 3" Hair Pin Clip	4
10.	SLL1201	Hitch Control Adjustment Link	1
11.	SLL1203	Hitch Control Pivot Link	1
12.	SLL1202	Hitch Control Wishbone Link	1
13.	SLL1204	Hitch Control Sleeve	1
14.	SOL-00B300	Hitch Control Slide Bar	1
15.	GHC-25080T	2-1/2" X 8" Tie Rod Hydraulic Cylinder	1

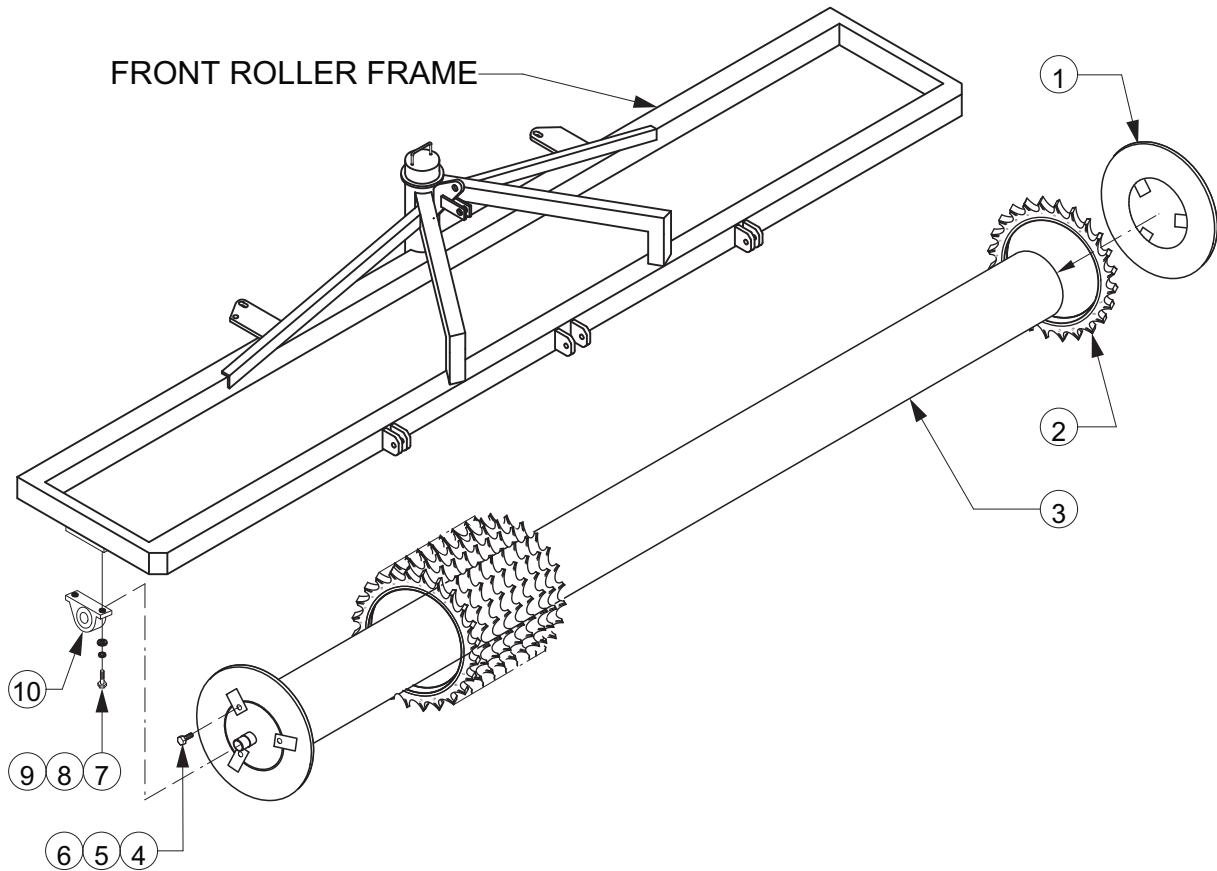

Tube - Rings Combination	TP Ring Size (ID/OD)	TP Ring Part #	Retainer Size (ID-OD)	Retainer Part #
10-12/16	12/16	TPP3351	10-14	TPP3206
12-14/20	14/20	TPP3353	12-16	TPP3210

Ref No.	Part No.	Description	Qty.
1.	-----	Ring Roller Retainer (refer to the table above for sizes)	2
2.	-----	Till An' Pak Roller Ring (refer to the table above for sizes)	varies
3.	-----	Till An' Pak Ring Roller Tube (specify size)	1
4.	CBNC510020	5/8" X 1-1/4" NC Carriage Bolt	6
5.	LWASHER-10	5/8" Lock Washer	6
6.	HXNUT-10NC	5/8" NC Hex Nut	6
7.	CSNC508036	1/2" X 2-1/4" NC Cap Screw Gr.5	4
8.	LWASHER-08	1/2" Lock Washer	4
9.	FWASHER-08	1/2" Flat Washer	4
10.	TPP3150	1-11/16" Pillow Block Bearing	2



WHEEL AXLE BEARING ASSEMBLY

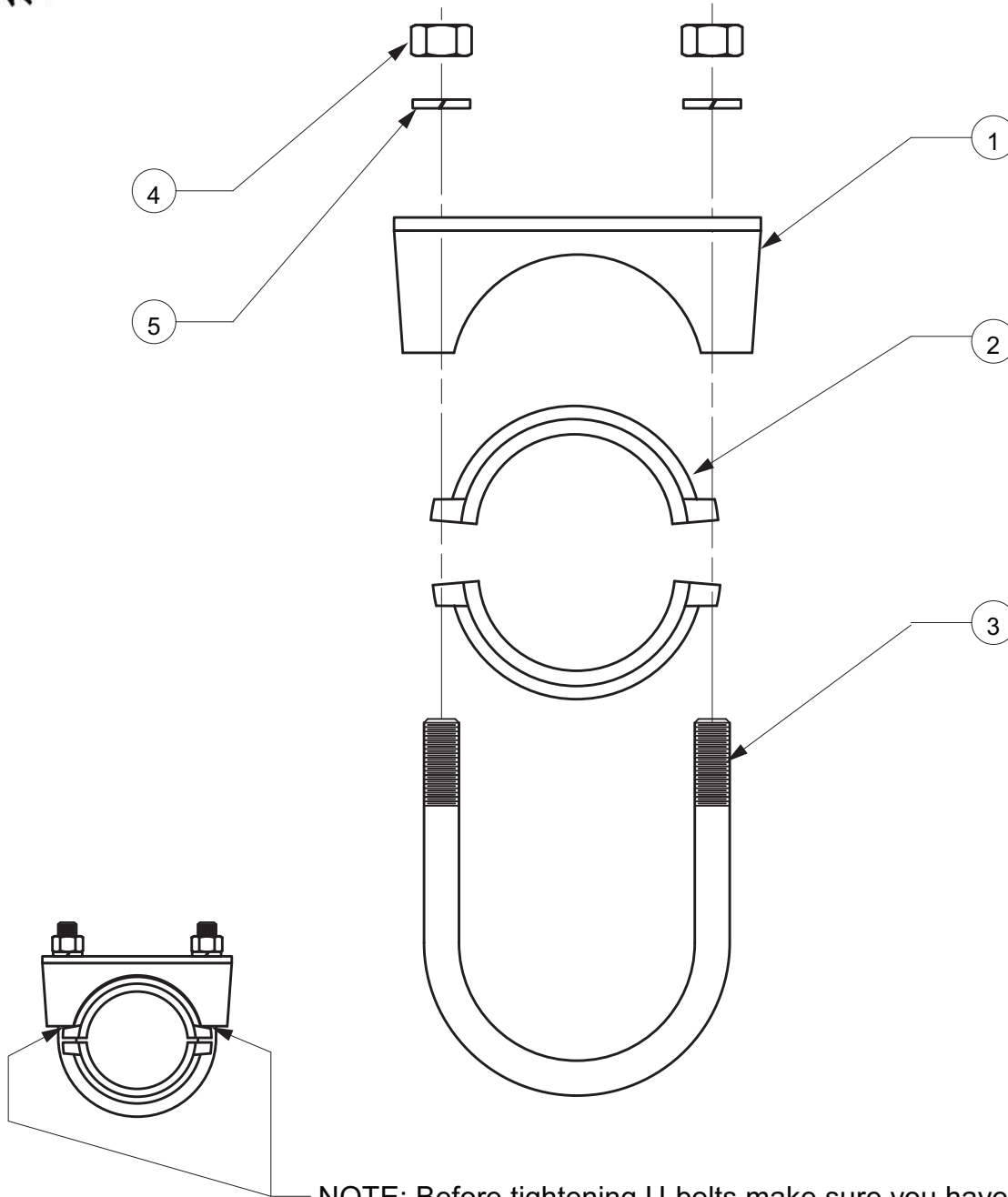

NOTE: Before tightening U-bolts make sure you have equal amount of space on each side.

<u>Ref No.</u>	<u>Part No.</u>	<u>Description</u>	<u>Qty.</u>
1.	SLL 1351	Bearing Cradle Cap Weldment	4
2.	SLL 1350	Bearing Cap Casting Machined	8
3.	UBNC16122R	1" Bearing U-bolt	4
4.	HXNUT-16NC	1" NC Hex Nut	8
5.	LWASHER-16	1" Lock Washer	8
	SLL 1352	U-Bolt Assembly (includes items 3, 4, and 5)	
	SLL 1353	Axle Bearing Assembly (includes items 1, 2, 3, 4, and 5)	

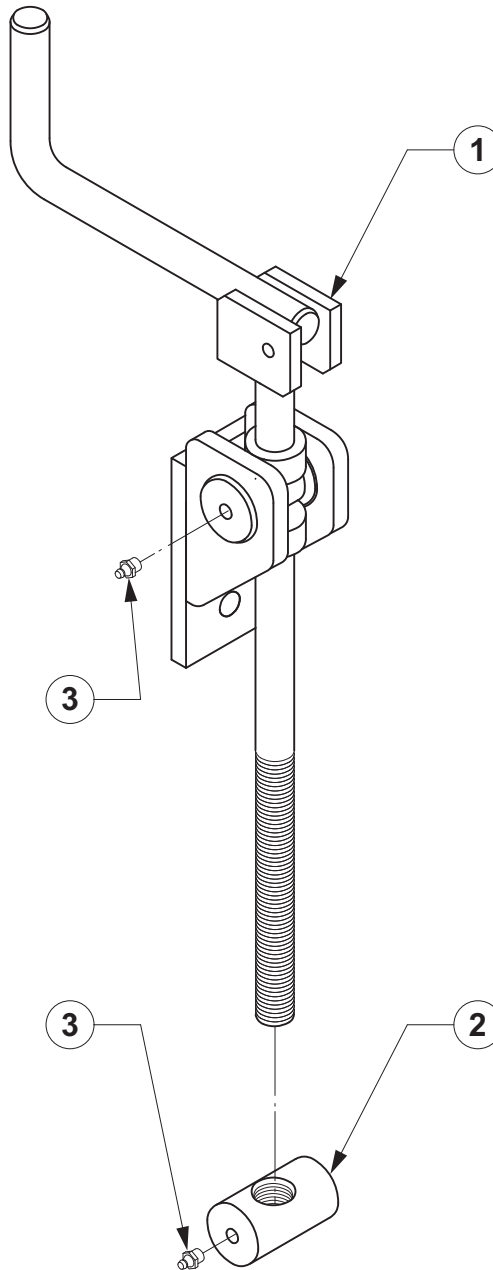

NOTE: Right Hand Crank shown

<u>Ref No.</u>	<u>Part No.</u>	<u>Description</u>	<u>Qty./ Unit</u>
1.	SLL1525R	Bucket Crank Assembly RH	1
	SLL1525L	Bucket Crank Assembly LH	1
2.	SLL1526	Bucket Crank Rod Nut ACME Thread	2
3.	GMB-ZERKDT	Drive Type Zerk Fitting	4



ORCHARD LEVELER WHEEL AXLE ASSEMBLY

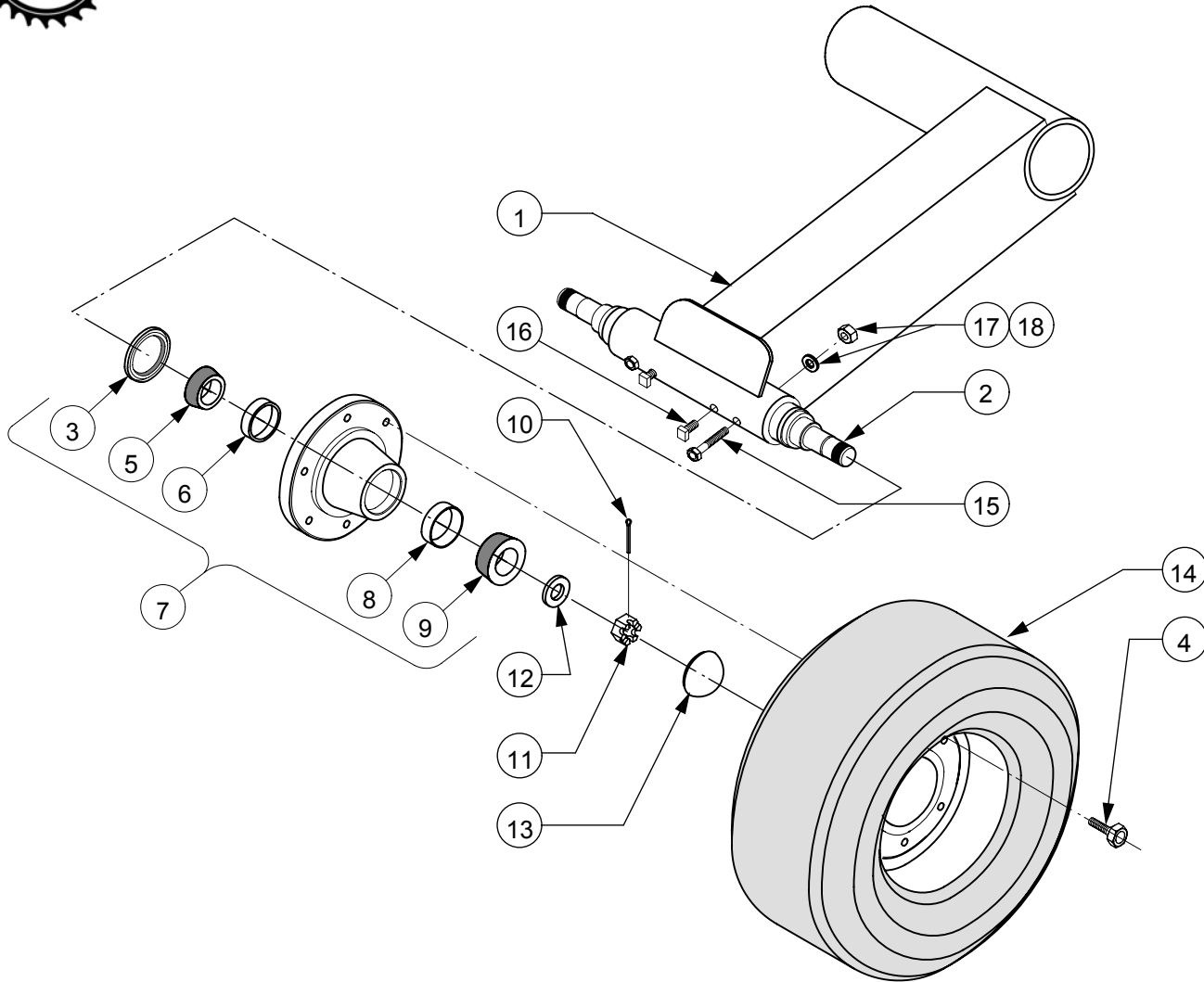

<u>Ref No.</u>	<u>Part No.</u>	<u>Description</u>	<u>Qty.</u>
1.	SOL-00E200	Orchard Leveler Wheel Axle Weldment	1
2.	TBU-01G016	2" x 20-1/4" Double Ended Removable Spindle	2
3.	GHB-6X6GSL	Grease Seal	4
4.	WHB-08X016	1/2" x 1" UNF Wheel Bolts for 6 on 6 Std. Hub	24
5.	GHB-6X6ICN	Inner Bearing Cone for 6 on 6 Std. Hub	4
6.	GHB-6X6IRC	Inner Bearing Cup for 6 on 6 Std. Hub	4
7.	GHB-6X6STD	Standard 6 on 6 Hub Assembly Complete (includes items 3, 4, 5, 6, 8, 9, 13)	4
8.	GHB-6X6ORC	Outer Bearing Cup for 6 on 6 Std. Hub	4
9.	GHB-6X6OCN	Outer Bearing Cone for 6 on 6 Std. Hub	4
10.	GSP-14SPWA	Spindle Washer	4
11.	GSP-14CANT	Spindle Castle Nut	4
12.	GPN-03X32C	3/16" x 2" Cotter Pin	4
13.	GHB-6X6CAP	Hub Cap	4
14.	GWT-761508	7.6 x 15 8 Ply Tire with Wheel	4
15.	CSNC506056	3/8" X 3-1/2" NC Gr.5 Cap Screw	4
16.	SSNCS08X16	1/2" X 1" NC Set Screw	4
17.	LWASHER-06	3/8" Lock Washer	4
18.	HXNUT-06NC	3/8" NC Hex Nut	4

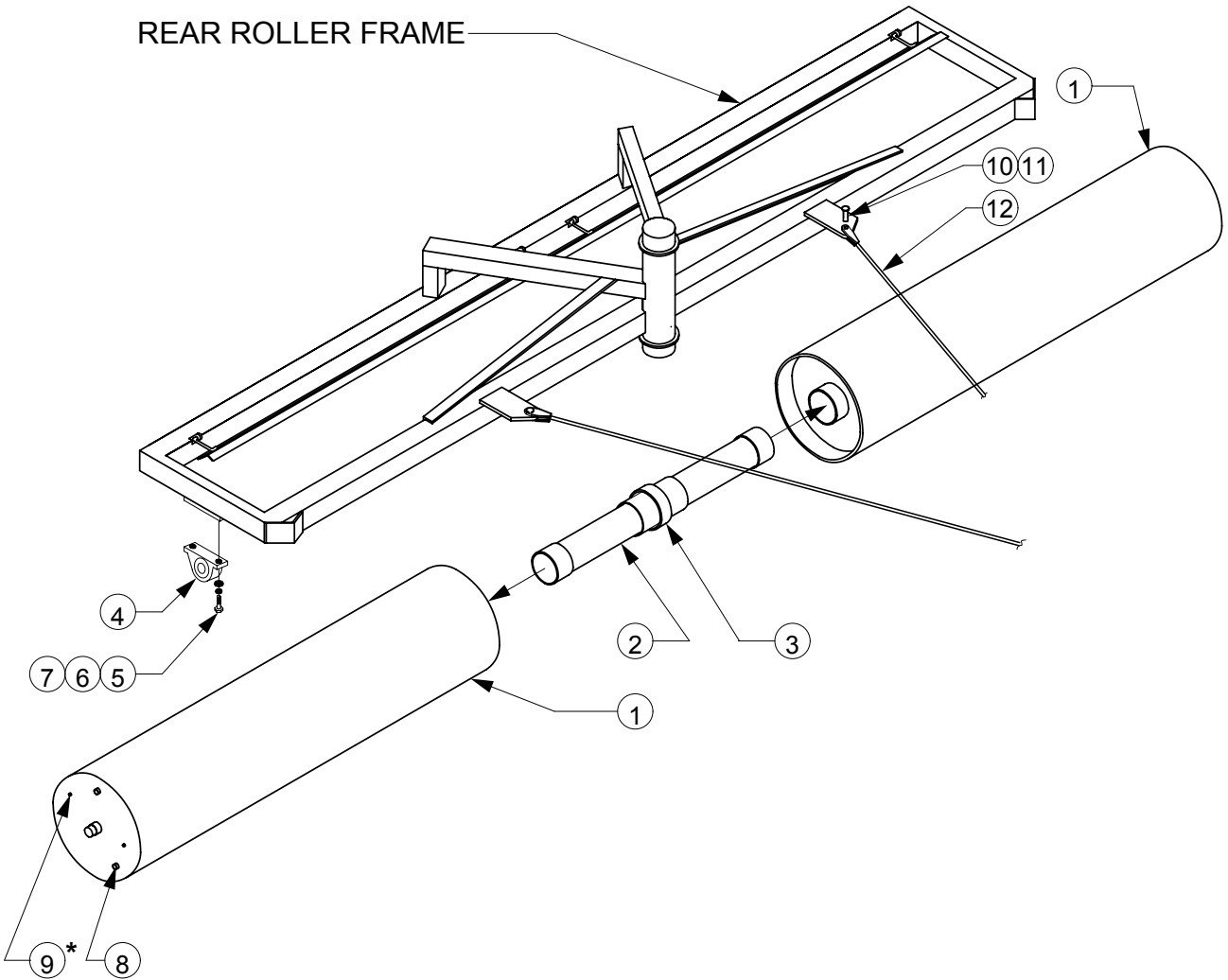

* NOTE: Be sure to grease differential shaft daily.

<u>Ref No.</u>	<u>Part No.</u>	<u>Description</u>	<u>Qty./ Roller</u>
1.	-----	Rear Split Roller (specify size)	2
2.	SOL-00J200	Orchard Leveler Differential Shaft	1
3.	SOL-00J205	OL Differential Shaft Collar	1
4.	TPP3150	1-11/16" Pillow Block Bearing	2
5.	CSNC508024	1/2" X 1-1/2" NC Cap Screw Gr.5	4
6.	LWASHER-08	1/2" Lock Washer	4
7.	FWASHER-08	1/2" Flat Washer	4
8.	PIPE08CPLG	1/2" Half Plug	4
9.	GMB-ZERKTH	Threaded grease zerk	4
10.	GPN-12X040	3/4" X 2-1/2" Pin	4
11.	GPN-04X40C	1/4" X 2-1/2" Cotter Pin	4
12.	SOL-00D200	Steering Rod Weldment	2

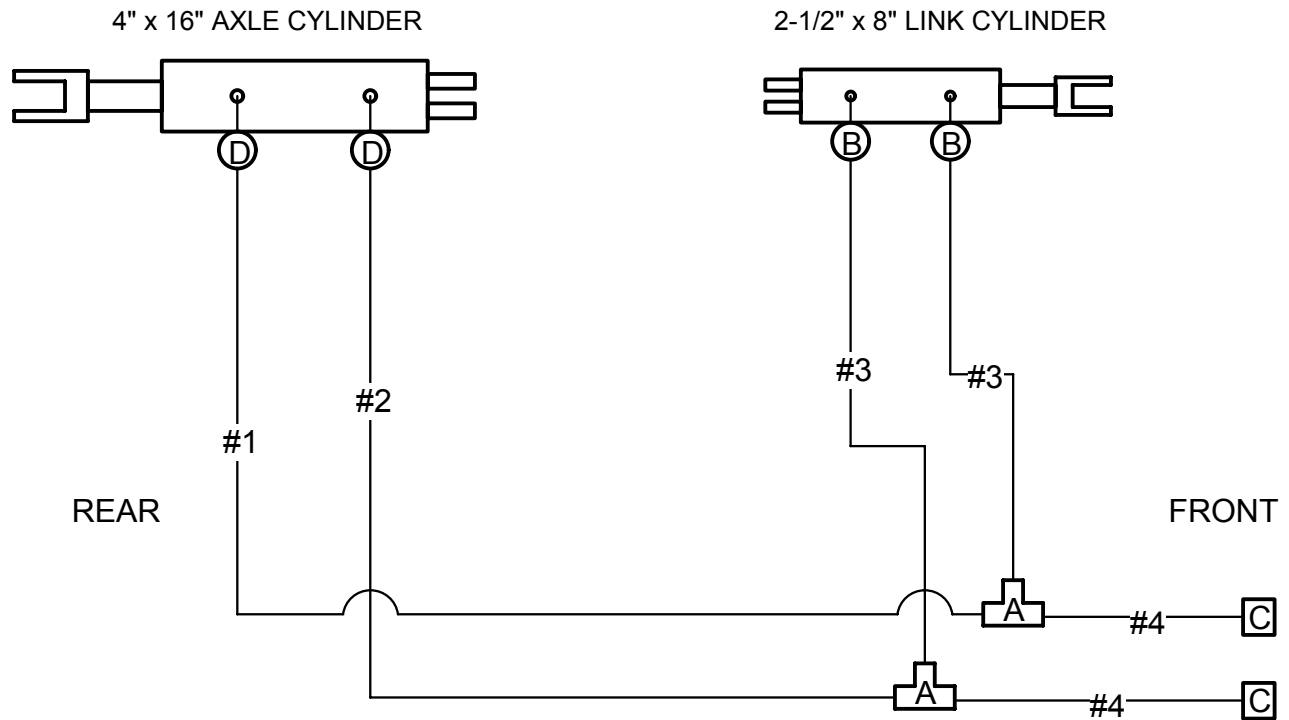

HOSES

	<u>Q-ty</u>
#1 - 8MP-8MPX 70" Long	(1)
#2 - 8MP-8MPX 51" Long	(1)
#3 - 8MP-8MPX 27" Long	(2)
#4 - 8MP-8MPX 138" Long	(2)

HYDRAULIC CYLINDERS

Part #	Description	Q-ty
GHC-40160T	4X16 Tie Rod Cyl.	(1)
GHC-25080T	2-1/2" X 8" Tie Rod Cyl.	(1)

FITTINGS

Ref. #	Part #	Description	Q-ty
A	FFPT080000	1/2" FPT "T" Fitting 3000# Cap.	(2)
B	FMBFP88C	8MB-8FP Straight	(2)
C	FFP08000PT	1/2" Pioneer Tip	(2)
D	FMPFPX9088	8MP-8FPX 90°	(2)

T.G. SCHMEISER CO., INC.®

Limited Warranty Statement

T. G. Schmeiser Co., Inc. warrants each new Schmeiser® product to be free from defects in material and workmanship. This warranty is applicable only for the normal service life expectancy of the product or components, not to exceed twelve (12) consecutive months from the date of delivery of the new Schmeiser product to the original purchaser.

Genuine T. G. Schmeiser Co., Inc. replacement parts and components will be warranted for 90 days from date of purchase, or the remainder of the original equipment warranty period, whichever is longer.

Under no circumstances will it cover any merchandise or components thereof, which, in the opinion of the company, has been subjected to misuse, unauthorized modifications, alteration, an accident or if repairs have been made with parts other than those obtainable through T. G. Schmeiser Co., Inc.

The Company in no way warrants engines, batteries, cylinders, tires or other trade accessories since these items are warranted separately by their respective manufacturer. Expendable components such as points, shanks, blades, rings, bearings, teeth, and the like are excluded from this warranty.

Our obligation under this warranty shall be limited to repairing or replacing, free of charge to the original purchaser, any part that, in our judgment, shall show evidence of such defect, provided further that such part shall be returned within thirty (30) days from date of failure to T. G. Schmeiser Co., Inc., routed through the dealer and distributor from whom the purchase was made, transportation charges prepaid.

This warranty shall not be interpreted to render T. G. Schmeiser Co., Inc. liable for injury or damages of any kind or nature to person or property. This warranty does not extend to the loss of crops, loss because of delay in harvesting, or any expense or loss incurred for labor, substitute machinery, rental or for any other reason.

Except as set forth above, **T. G. Schmeiser Co., Inc. shall have no obligation or liability of any kind on account of any of its equipment and shall not be liable for special or consequential damages. T. G. Schmeiser Co., Inc. makes no other warranty, expressed or implied, and, specifically, T. G. Schmeiser Co., Inc. disclaims any implied warranty or merchantability or fitness for a particular purpose.** This warranty is subject to any existing conditions of supply, which may directly affect our ability to obtain materials or manufacture replacement parts.

T. G. Schmeiser Co., Inc. reserves the right to make improvements in design or changes in specifications at any time, without incurring any obligation to owners of units previously sold.

No one is authorized to alter, modify or enlarge this warranty nor the exclusion, limitations and reservations.

**WARRANTY VOID IF NOT REGISTERED
WITHIN 30 DAYS OF PURCHASE DATE**

Notes

A large rectangular box with a black border, containing 15 horizontal gray bars for writing notes. The bars are arranged in a repeating pattern of gray and white, providing a structured space for taking notes.

Notes

A large rectangular box with a black border, containing 15 horizontal gray bars for writing notes. The bars are arranged in a repeating pattern of gray and white, providing a structured space for taking notes.